

5-2 ARK 2.5H-A1 Connection end face introduction

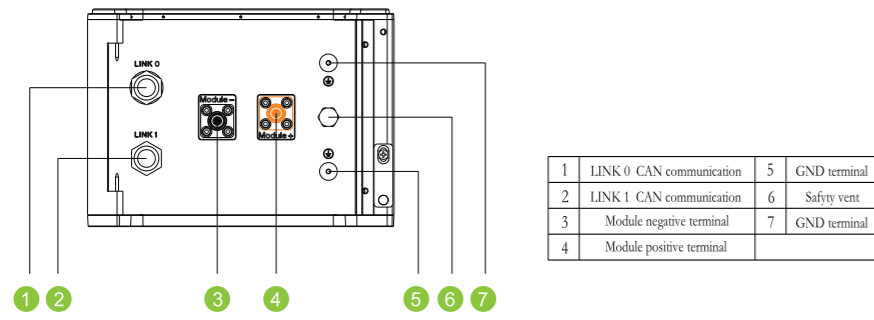

5-3 Diagram of wiring connection

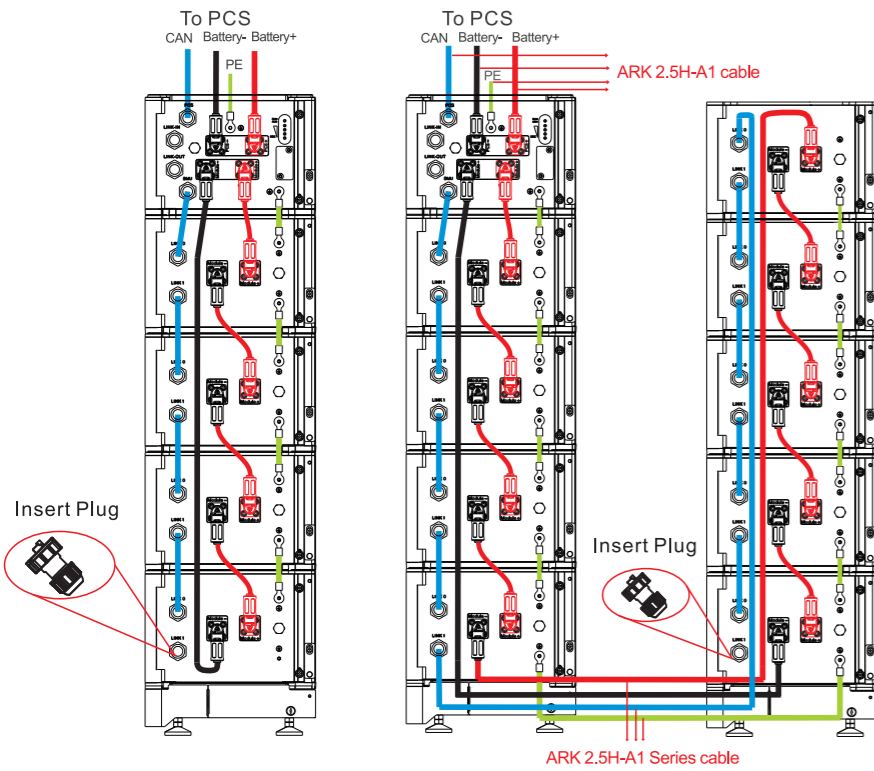

6.Terminal Connection

6-1 Power terminal

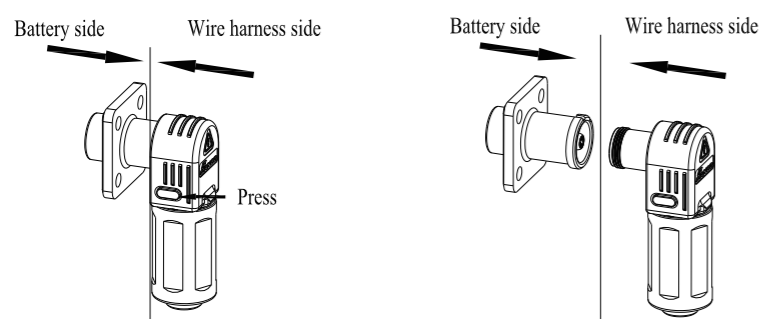

6-2 Communication terminal

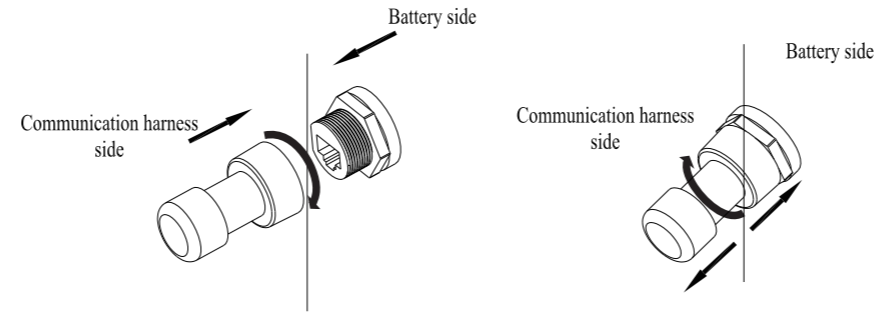

7.Battery system switch operation

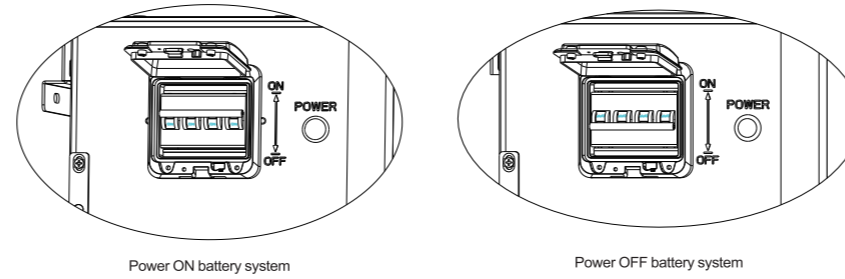

**Power ON battery system:**  
Turn the circuit breaker to the "ON" state, press the POWER button for 5-6 seconds, wait for the battery system LED light to light up, indicating that the boot is complete.

**Power off battery system:**  
Turn the breaker of to "OFF" to turn off the entire battery system.

8.Key operation

Power Button

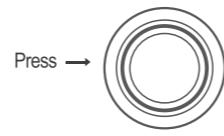
Situation	Touch	Definition	
System off	Press(≥5S)	Power on	

**Note:** When multiple battery system are used in parallel connection, you only need to press one key of any module to start the system.

9.Service and contact

**Shenzhen Growatt New Energy CO.,Ltd**  
No. 28 Guangming Road,Shiyan Street,Bao'an District, Shenzhen,P.R.China  
☎ 86 0755 2747 1942    ✉ service@ginverter.com  
W:www.ginverter.com



Installation environment

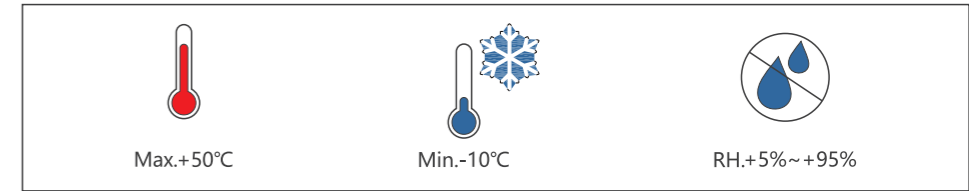

Installation tools

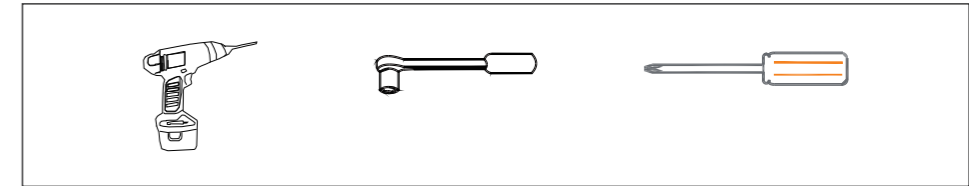

System size

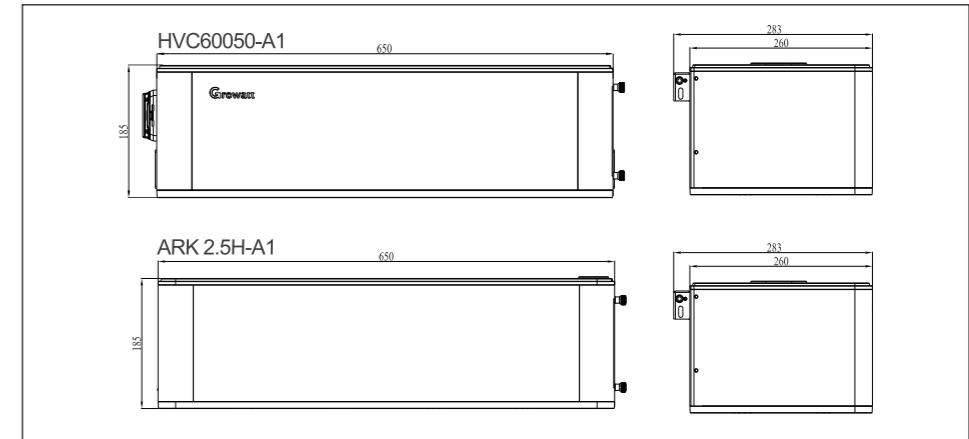

1.Check

1-1 Check HVC60050-A1 List

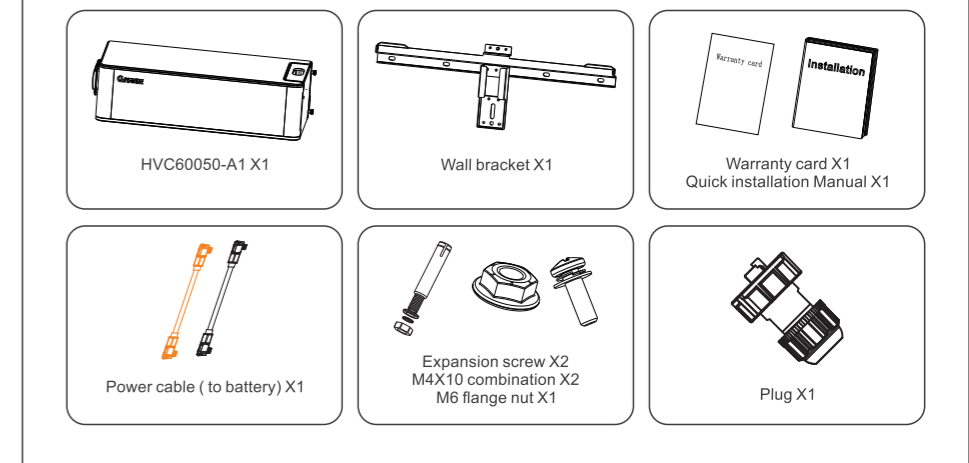

1-2 Check ARK 2.5H-A1 List

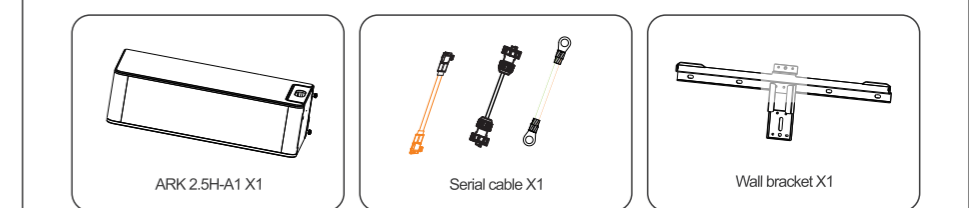

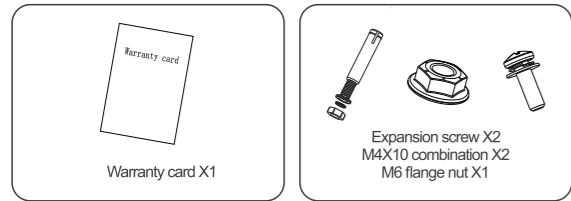

### 1-3 Check accessories

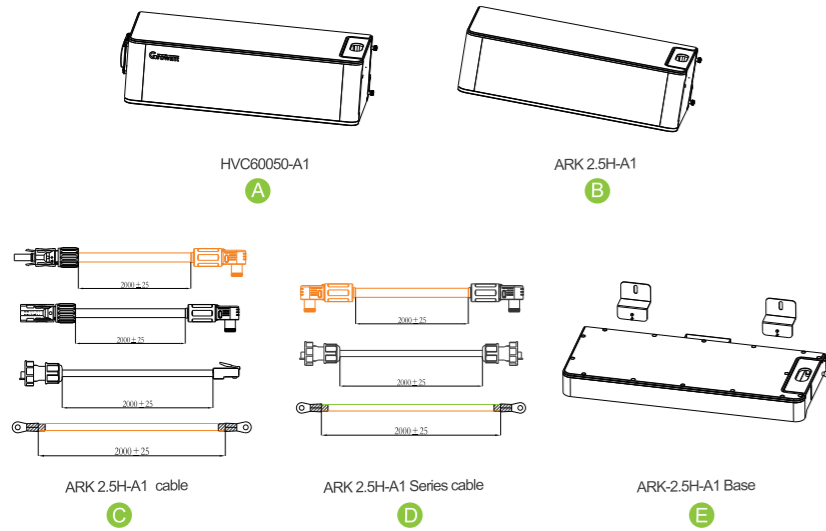

Installation Method	Compound Mode
Standard Wall-Mounted Installation	A+B+C
Standard floor installation	A+B+C+E
Wall-Mounted Battery system stacked in two line	A+B+C+D
Floor installation battery system stacked in two line	A+B+C+D+E*2

## 2. Floor installation with base

### 2-1 Installation Location Requirements

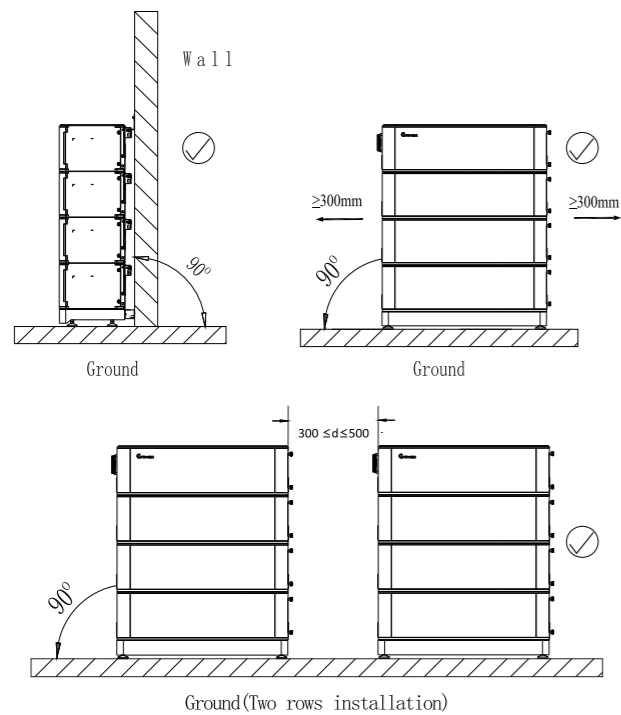

**Note:** 1. If more than 4 batteries are used, base mounting is recommended.  
2. For floor installation with base, the maximum stack number of the battery is ten. But if the battery number is greater than six, we recommend stacking them in two lines.

## 2-2 Installation Procedure

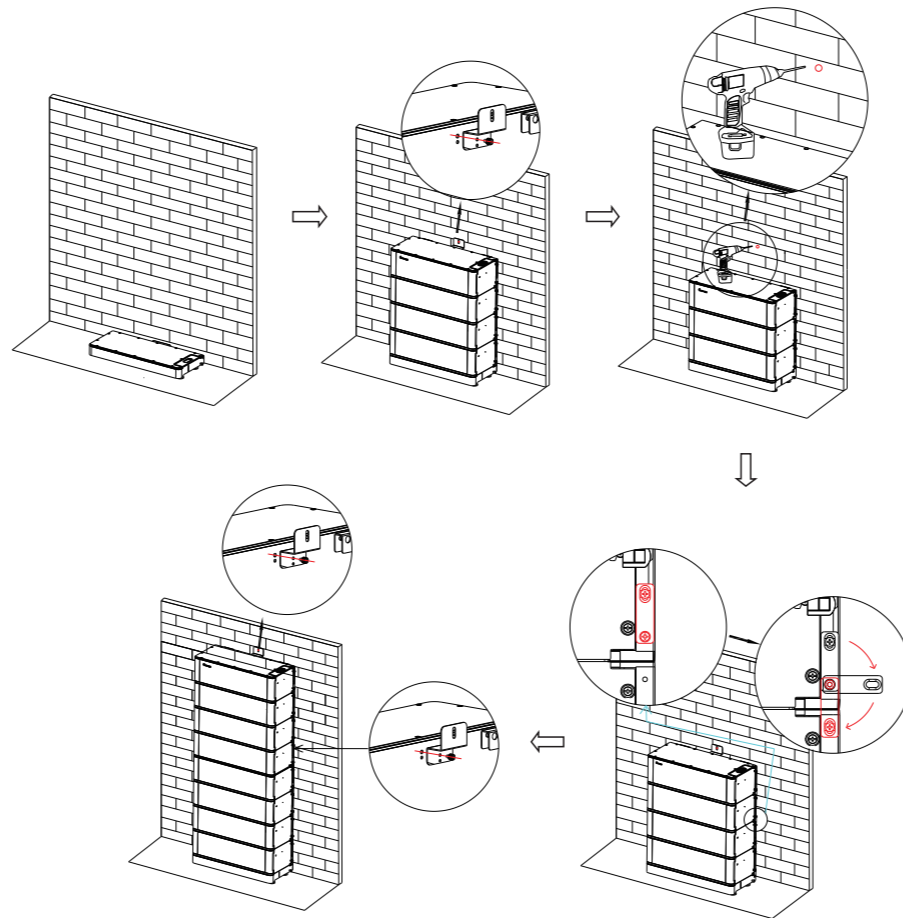

**Note:** The safety part needs to be installed at the top battery, however, once the number of the battery pack is higher than 7, one more safety part should be installed in the middle battery which is shown the last step.

## 3. Wall-Mounted Installation Process

### 3-1 Installation Location Requirements

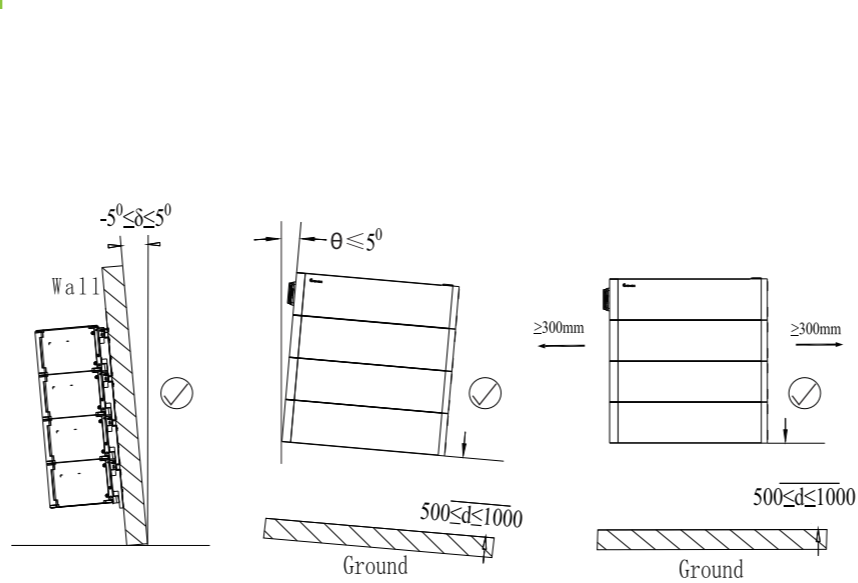

**Note:** The number of wall-mount installations should not exceed four. Please make sure that the weight capacity of wall should exceed 150kg.

## 3-2 Installation Procedure

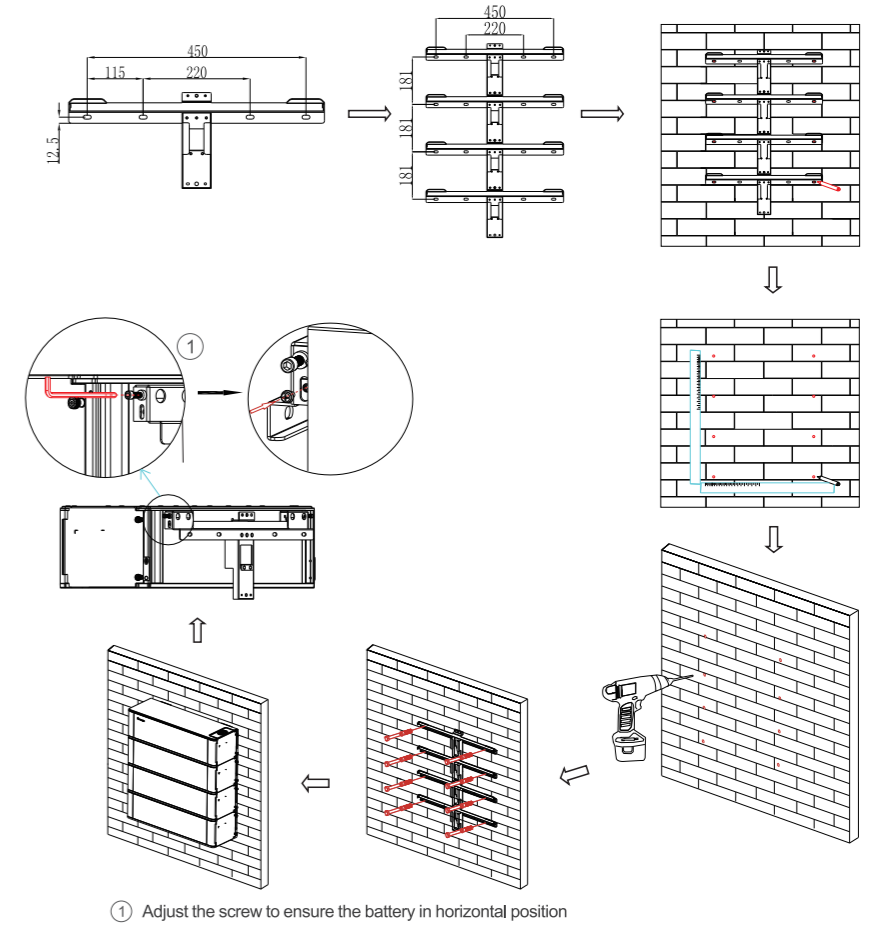

## 4. Install Environment

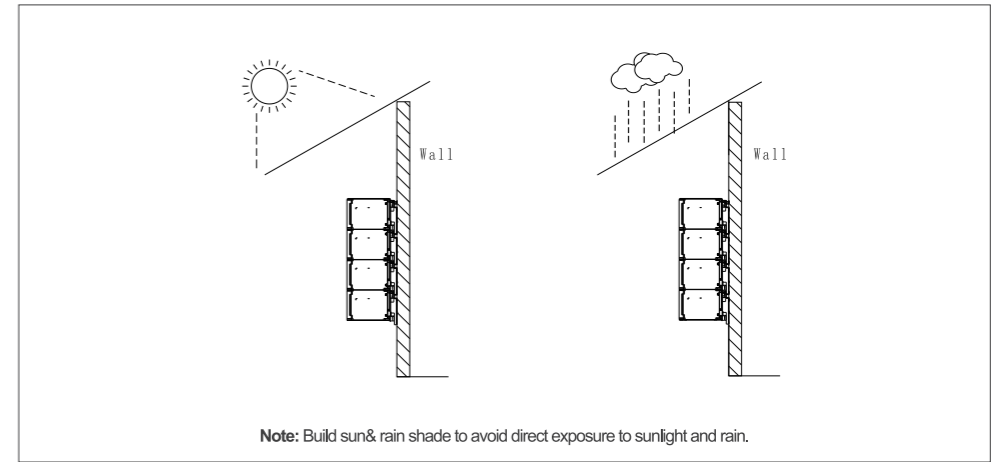

**Note:** Build sun & rain shade to avoid direct exposure to sunlight and rain.

## 5. Wire Connection

### 5-1 HVC60050-A1 Connection end face introduction

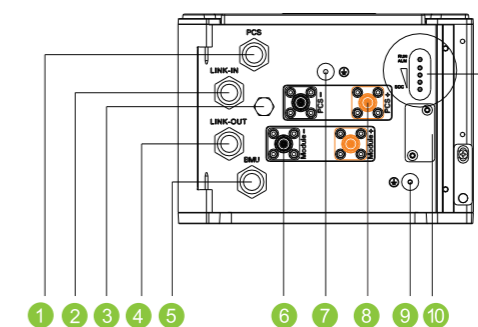

1	PCS CAN communication	7	GND terminal
2	LINK-IN CAN communication	8	PCS terminal
3	Safety vent	9	GND terminal
4	LINK-OUT CAN communication	10	USB interface
5	BMU CAN communication	11	LED
6	Module terminal		