



# Quick Installation Guide

22KW Fox ESS AC EV Charger

Please read this guide carefully to prevent improper operation before use.

# 1. Packing List

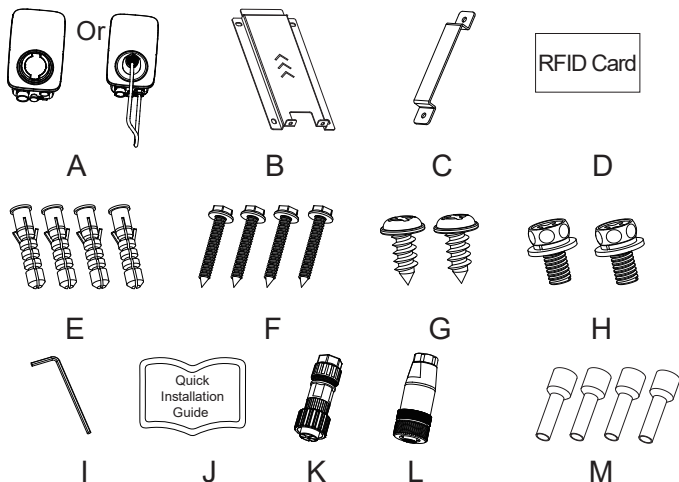

S/N	Name	Quantity
A	EV Charger (EV Plug or Plug Holder)	1
B	Mounting Backplate	1
C	Mounting Bracket	1
D	RFID Card	2
E	Φ8*40mm Expansion Pipe	4
F	ST6*40 Expansion Screw	4
G	ST4.2*9.5mm Self-tapping Screw	2
H	M4*10mm Screw Assembly	2
I	2mm Socket Head Wrench	1
J	Quick Installation Guide	1
K	AC Connector	1
L	DC Connector	1
M	E0508 Tubular Terminal	4

## 2. Product Icon

### ① Meaning of lights

- Green breathing light - standby status
- Blue Steady - EV Plug inserted status
- Blue breathing light - charging start status/ pause
- Blue running light - charging status
- Green Steady - charging end status
- Red Steady - Charger fault, shutdown protection
- Yellow Steady - locked status

### ② Plug holder

### ③ RS485 Communication wire

### ④ Incoming cable

### ⑤ Stop button

### ⑥ Mounting Bracket

### ⑦ Mounting Backplate

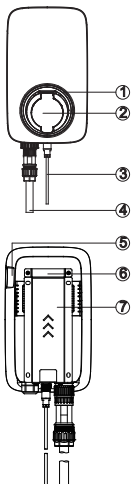

## 3. Installation Preparation

1. The EV Charger can be installed on a flat surface that can support its weight (such as walls, columns, etc.).

2. Please install an EV Charger where the EV Plug cable can be connected to the vehicle charging port (without pulling the cable).

3. The recommended installation height of the EV Charger is 700~1500mm.

4. Do not install the EV Charger in an environment that may cause damage to it.

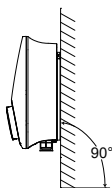

Vertical ✓

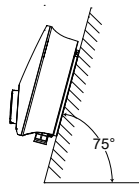

Tilt Backward ✓

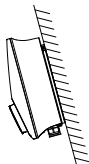

Tilt Forward ⚠

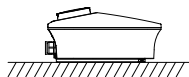

Level ⚠

Installation Schematic Diagram

## 3.1 Wall Mounted Installation Method

### Step 1

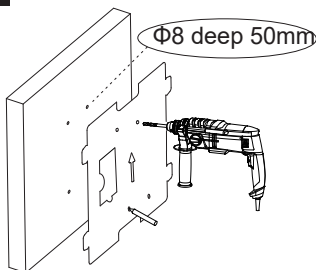

1. Mark 4 holes according to the installation positioning card on the wall.
2. Use an 8mm drill bit to drill holes (with a hole depth of over 50mm).
3. Clean the hole position.

### Step 2

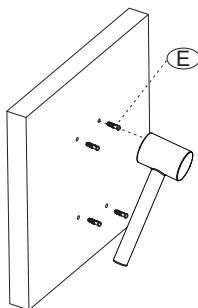

Insert the expansion pipe (E) into the hole and fix it tightly with a rubber hammer.

### Step 3

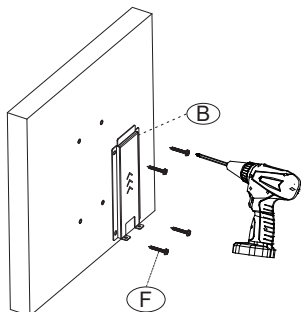

Fix the Mounting backplate (B) to the wall with screws (F).

#### Step 4

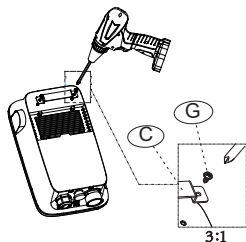

Fix the Mounting bracket (C) onto the EV Charger with screws (G).

#### Step 5

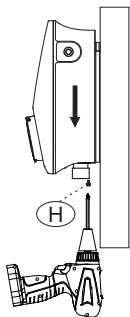

1. Hang the EV Charger into the Mounting backplate.
2. Tighten the screws (H) to complete the installation.

## 3.2 Floor/Vertical installation Method

### Step 1

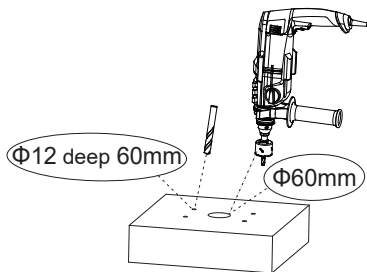

1. Use a 12mm drill bit to drill four 60mm deep holes with a spacing of 170\*120mm.
2. Drill one Φ60mm outlet hole in the center.
3. Clean the hole position.

### Step 2

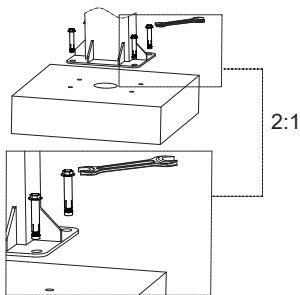

Install the foot screw and fix with a wrench.

### Step 3



Router the input wire into the column hole through the ottom of the column.

#### Step 4

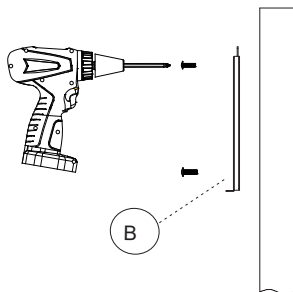

Fix the Mounting backplate (B) to the column with screws.

#### Step 5

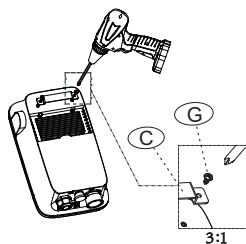

Fix the bracket (C) onto the EV Charger with screws (G).

#### Step 6

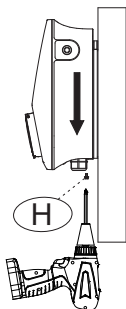

1. Hang the EV Charger into the Mounting backplate.
2. Tighten the screws (H) to complete the installation.

### 3.3 Electrical Connections

A leakage protection switch needs to be installed. The leakage protection switch should use Type A, not less than 32A, and the input wire should be led out from the leakage protection switch. It is recommended to use 6~10 AWG (wire diameter 6~16mm<sup>2</sup>) cable.

Trim all cables to 75mm (as shown in the figure) and peel off the insulation sheath to expose the conductor by about 16mm.

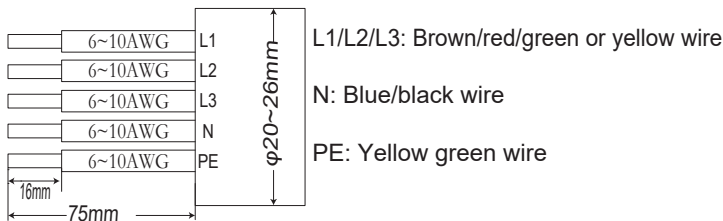

Note: Please refer to the local cable model and color during actual installation

#### Step 1

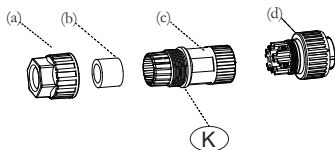

Divide the AC connector (K) into four parts: nut (a), sealing ring (b), sleeve (c), and plug (d).

#### Step 2

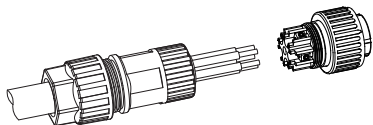

Thread the cable through the nut (a), sealing ring (b), and sleeve (c) in sequence, and screw the nut onto the sleeve (do not tighten it yet).



### Step 3

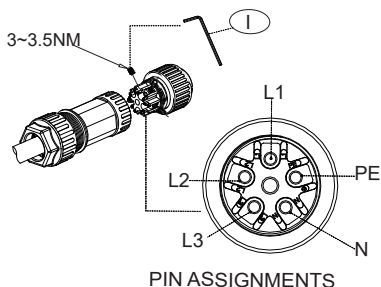

Install the cable into the plug (D) of the AC connector as shown in the figure below, and tighten the screw with a 2mm Allen wrench (I).

### Step 4

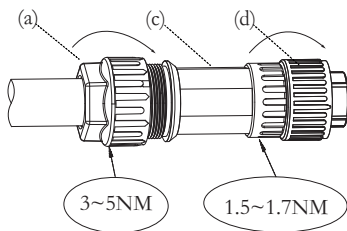

First, tighten the nut (a) and sleeve (c) with 3-5 NM torque, and then tighten the sleeve(c) and plug (d) with 1.5-1.7 NM torque to complete the internal wiring of the AC connector.

### Step 5

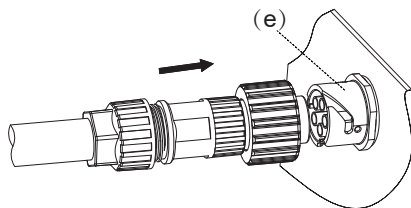

Insert the plug (d) of the AC connector into the socket (e) of the junction box, and tighten the plug (d) to complete the installation.

### 3.4 Communication wiring (The communication wire is required only if an electric meter is available on the site of use)

Trim all cables (wire diameter  $0.3\text{mm}^2$ ) to 15mm (as shown in the figure), peel off the insulation sheath to expose the conductor by about 8mm.

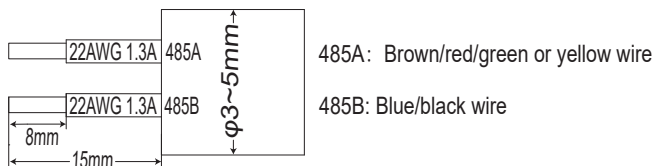

Note: Please refer to the local cable model and color during actual installation

#### Step 1

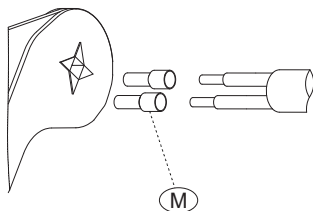

Use crimping pliers to crimp the tubular terminal (M) and cable.

#### Step 2

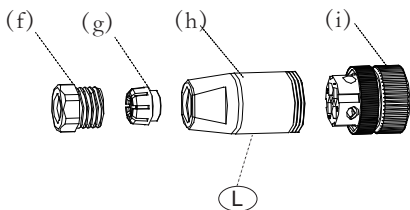

Divide the DC connector into four parts: nut (f), sealing ring (g), sleeve (h), and plug (i).

### Step 3

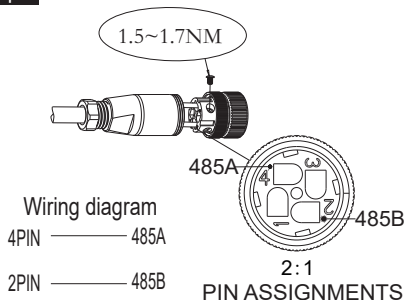

Thread the cable through the nut (f), sealing ring (j), and sleeve (h) in sequence. Thread the nut onto the sleeve (do not tighten it yet), then insert the cable tubular terminal (M) into the plug (i) of DC connector, and tighten the screw.

### Step 4

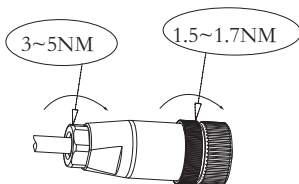

First tighten the nut (f) and sleeve (g) with 3-5 NM torque, and then tighten the sleeve (h) and plug (i) with 1.5-1.7 NM torque.

### Step 5

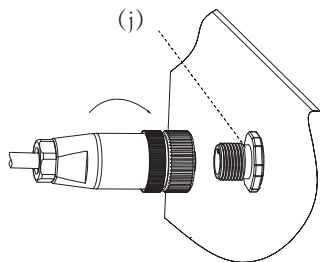

Insert the plug (f) of the DC connector into the socket (j) of the junction box, and tighten the plug (i) to complete the installation.

Users can download the (Android and IOS) APP by scanning the QR code in the Quick Installation Manual, or search for Elite Charger through the App Store and Google Play.

Obtain the APP QR code



Please follow the steps below to download our latest multilingual manual/Quick Installation Guide;

Scan QR code → Select your language → Select to download User Manual or Quick Installation Guide → Download

Obtain User Manual QR code



Address: Longwan District,Wenzhou, China

Tel: +86(510) 68092998(General)  
+86(510) 68101679 (Sales)

Website: [www.fox-ess.com](http://www.fox-ess.com)



V1.1

10-203-00407-01